

ELECTRIC TORQUE WRENCH

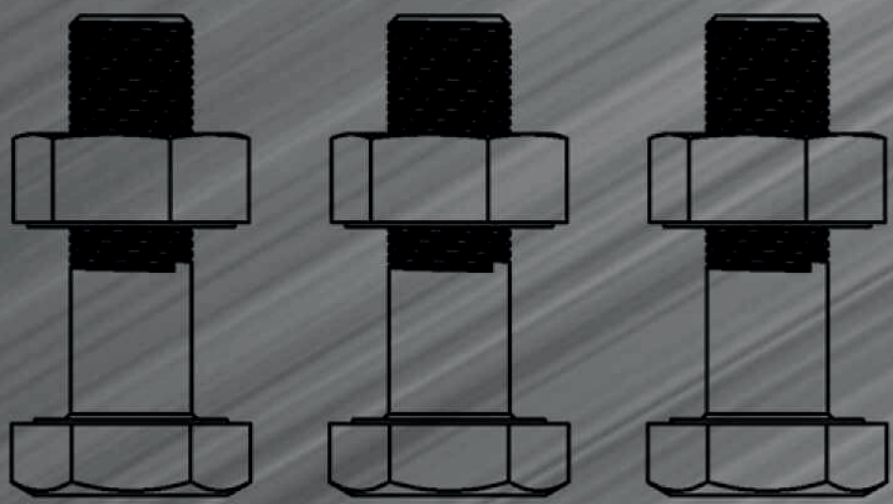

CHARACTERISTICS

Small volume, Light weight, Easy to control.
Adopt digital controller, accurate and reliable.

50-60Hz
220V/115V

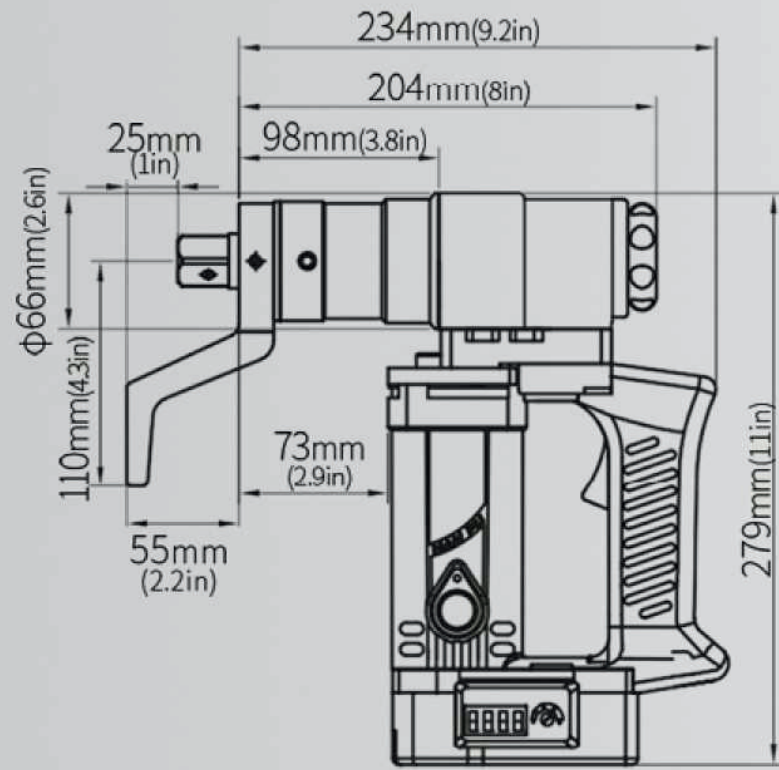
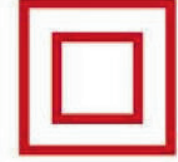

ELECTRIC TORQUE WRENCH **BTDEC-3B**

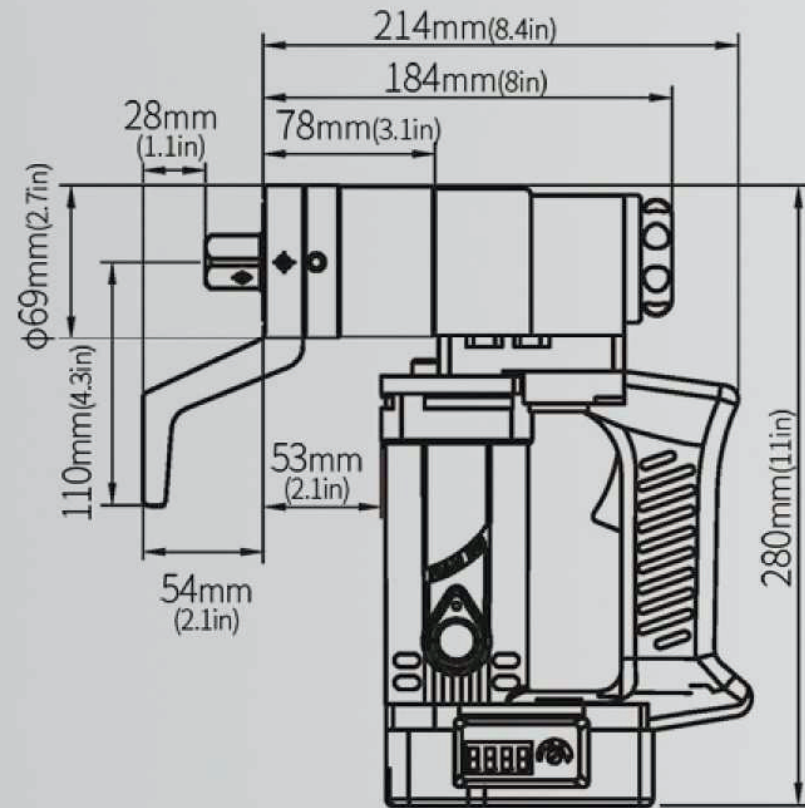

ELECTRIC TORQUE WRENCH **BTDEC-5B**

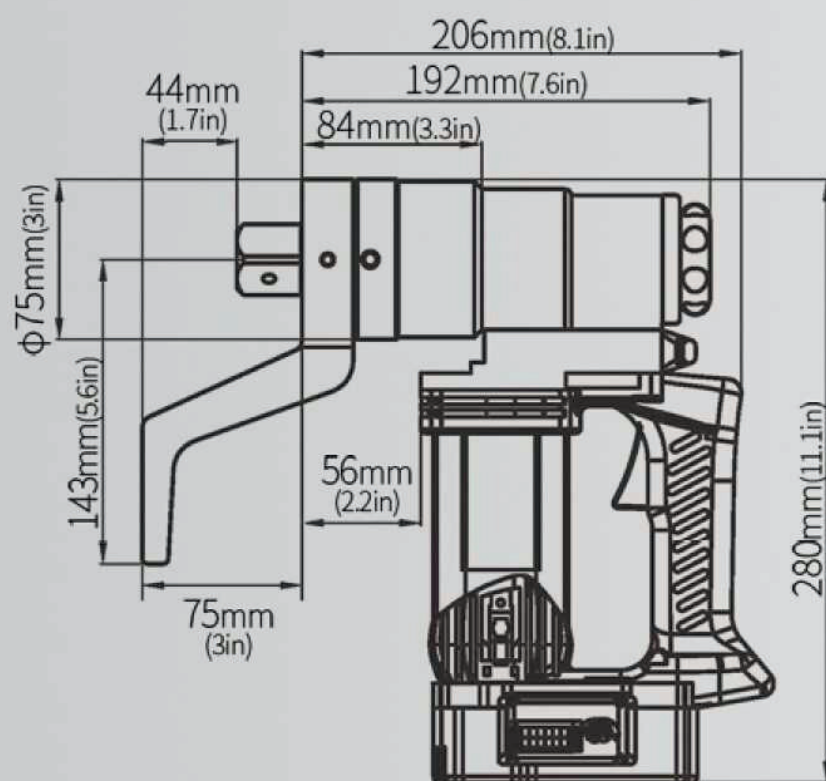

ELECTRIC TORQUE WRENCH **BTDEC-10LP**

MODEL	MAX CURRENT	MAX POWER CONSUMPTION	TORQUE RANGE	RO SPEED (min-1)	WEIGHT (MAIN BODY)	SQUARE DRIVE	ADAPTABLE BOLTS DIA		
							S-10T	A325	A490
BTDEC-3B	6A 12A	1300W	100-300N.m 74-221lbs.ft	24rpm	4.4KG	19X19mm (3/4"X3/4")	M12 M16	1/2" 5/8"	1/2"
BTDEC-5B	7A 14A	1650W	200-500N.m 148-369lbs.ft	15.5rpm	4.5KG	19X19mm (3/4"X3/4")	M16 M20	5/8" 3/4"	5/8"
BTDEC-10LP	7A 14A	1650W	300-1000N.m 220-738lbs.ft	14rpm	5KG	25.4X25.4mm (1"X1")	M20 M22 M24	3/4" 7/8" 1"	3/4" 7/8"

wrench without socket



CHARACTERISTICS

Small volume, light weight, Suitable for high altitude and narrow space work. Digital control torque, high repeated accuracy and stability. Can control both torque value and rotational angle. Torque and angle can be separately or simultaneously controlled.

50-60Hz
220V/115V

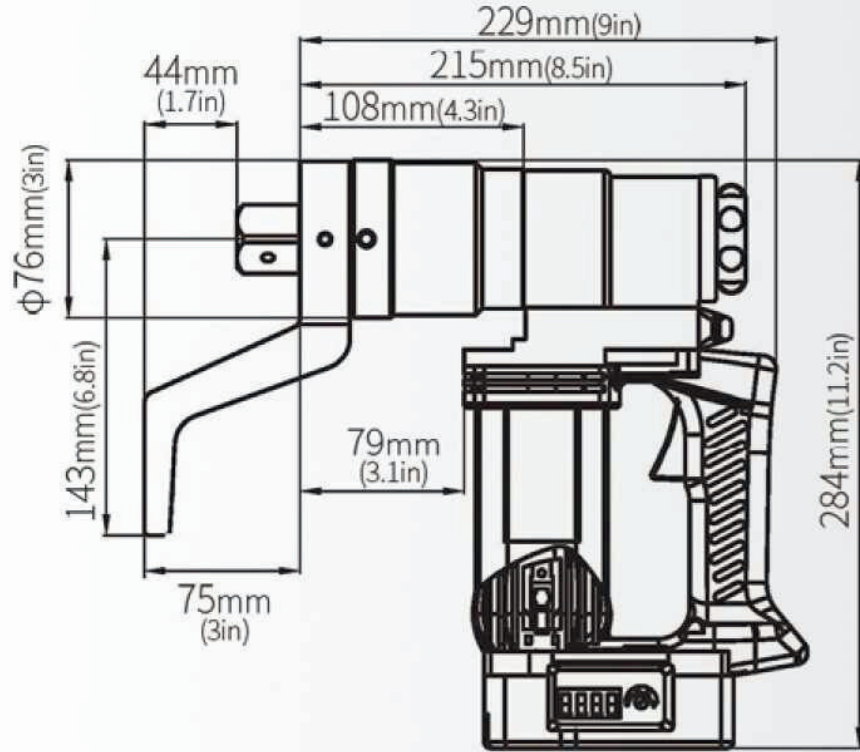
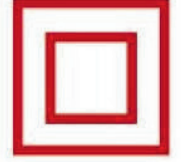

ELECTRIC TORQUE WRENCH **BTDEC-12LP**

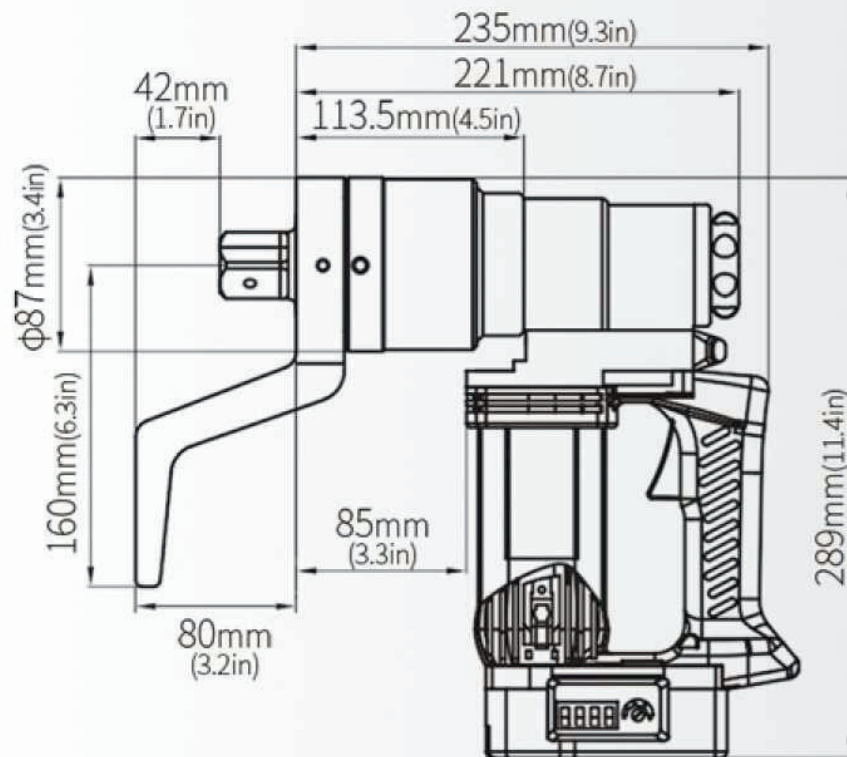

ELECTRIC TORQUE WRENCH **BTDEC-21LP**

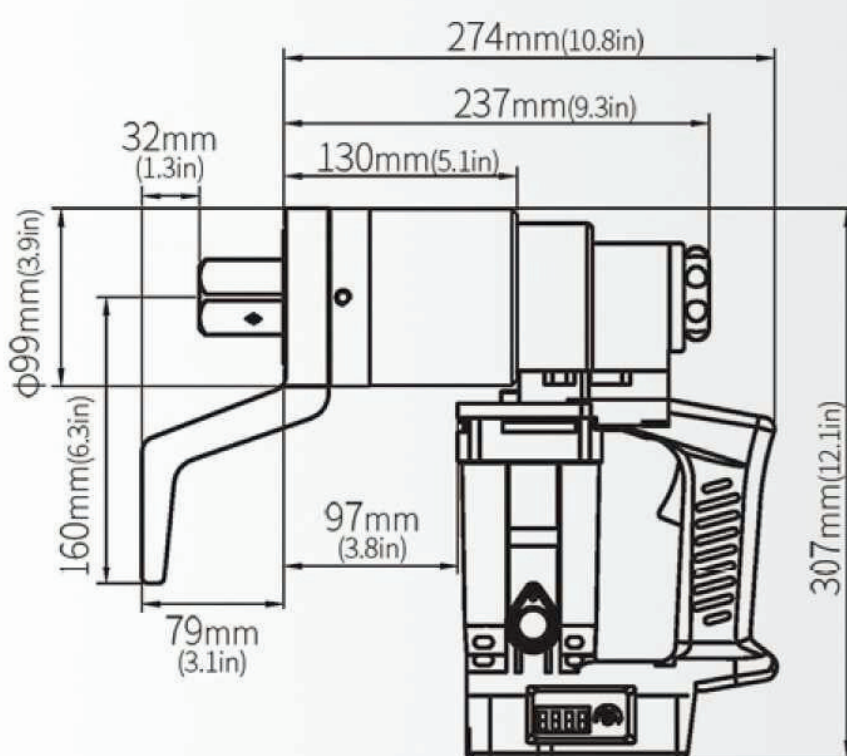

ELECTRIC TORQUE WRENCH **BTDEC-25G**

MODEL	MAX CURRENT	MAX POWER CONSUMPTION	TORQUE RANGE	RO SPEED (min-1)	WEIGHT (MAIN BODY)	SQUARE DRIVE	ADAPTABLE BOLTS DIA		
							S-10T	A325	A490
BTDEC-12LP	8A 16A	1800W	500-1200N.m 369-886lbs.ft	9rpm	5.5KG	25.4X25.4mm (1"X1")	M22 M24	7/8" 1"	7/8" 1"
BTDEC-21LP	8A 16A	1800W	900-2100N.m 664-1550lbs.ft	6rpm	6.6KG	25.4X25.4mm (1"X1")	M27 M30	1-1/8" 1-1/4"	1-1/8" 1-1/4"
BTDEC-25G	12A 24A	2800W	1000-2500N.m 738-1845lbs.ft	5rpm	9KG	38X38mm (1-1/2"X1-1/2")	M27 M30 M33	1-1/8" 1-1/4" 1-3/8"	1-1/8" 1-1/4"

wrench without socket



ELECTRIC TORQUE WRENCH

CHARACTERISTICS

Small volume, light weight, Suitable for high altitude and narrow space work. Digital control torque, high repeated accuracy and stability. Can control both torque value and rotational angle. Torque and angle can be separately control, also can be controlled at the same time.

50-60Hz
220V/115V

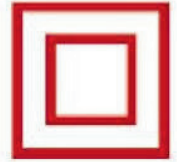

NEW

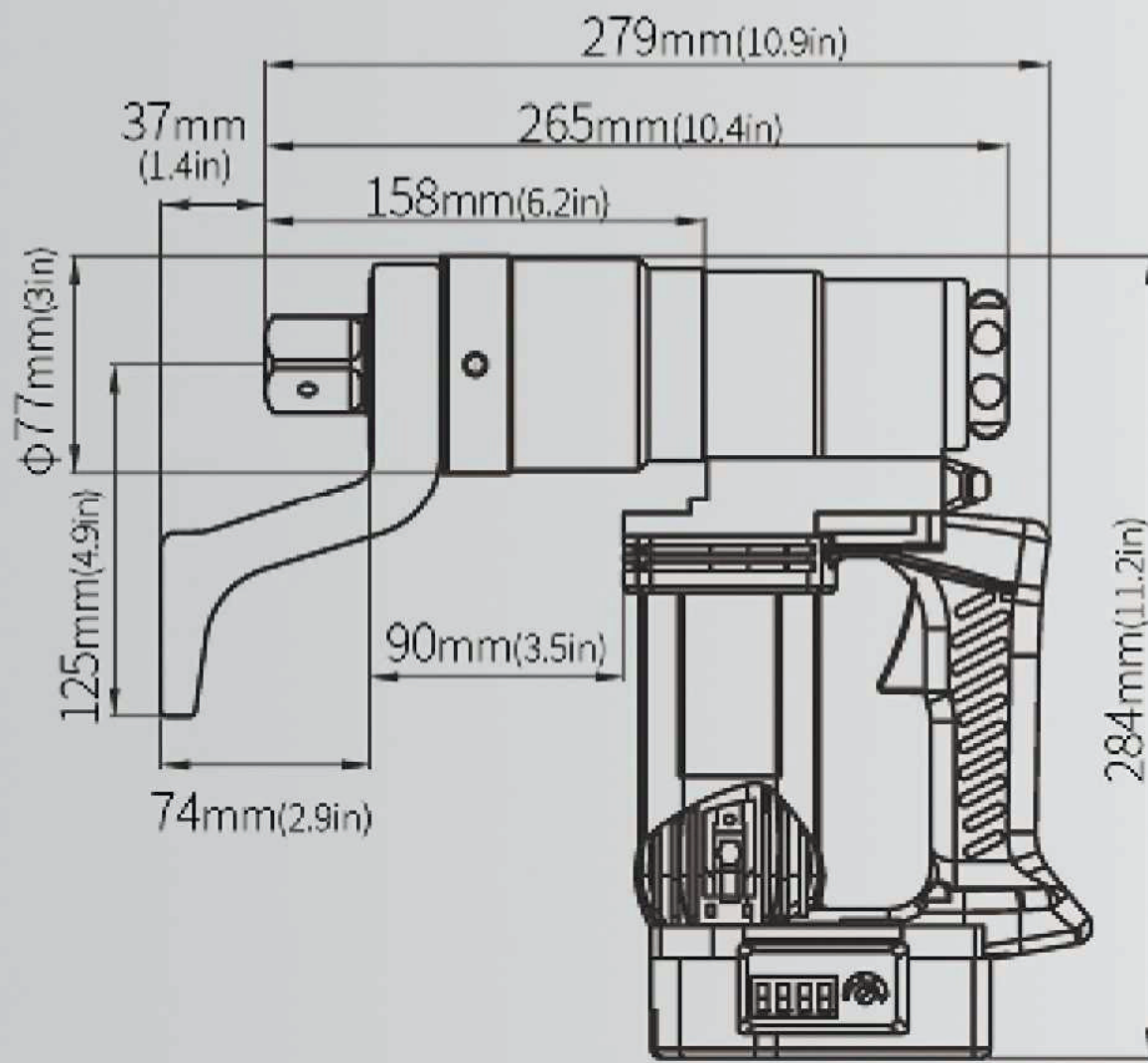

ELECTRIC TORQUE WRENCH **BTDEC-15LP**

MODEL		BTDEC-15LP
FREQ		50-60Hz
VOLTAGE		230v/115V
MAX CURRENT		8A/16A
MAX POWER CONSUMPTION		1800W
TORQUE RANGE		500-1500N.m(369-1107lbs.ft)
RO SPEED(min-1)		10rpm
WEIGHT(MAIN BODY)		5.5KG
SQUARE DRIVE		25.4X25.4mm(1"X1")
ADATTABLE BOLTS DIA	S-10T	M22 M24 M27
	A325	7/8" 1" 1-1/8"
	A490	7/8" 1"

wrench without socket

NEW

ELECTRIC TORQUE WRENCH

CHARACTERISTICS

Digital control torque, high repeated accuracy and stability. Can control both torque value and rotational angle. Torque and angle can be separately control, also can be controlled at the same time.

50-60Hz
220V/115V

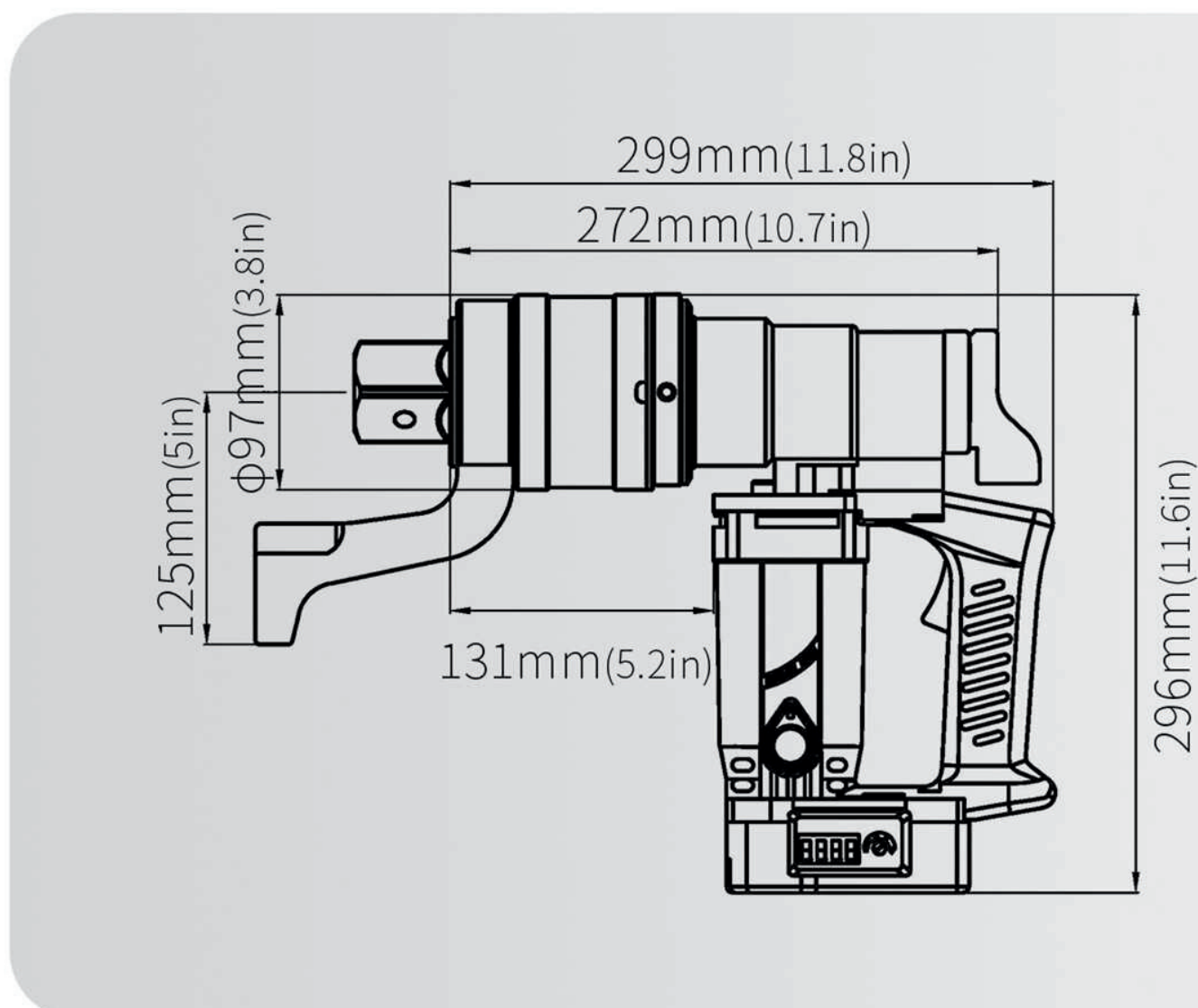
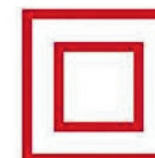

ELECTRIC TORQUE WRENCH BTDEC-40G

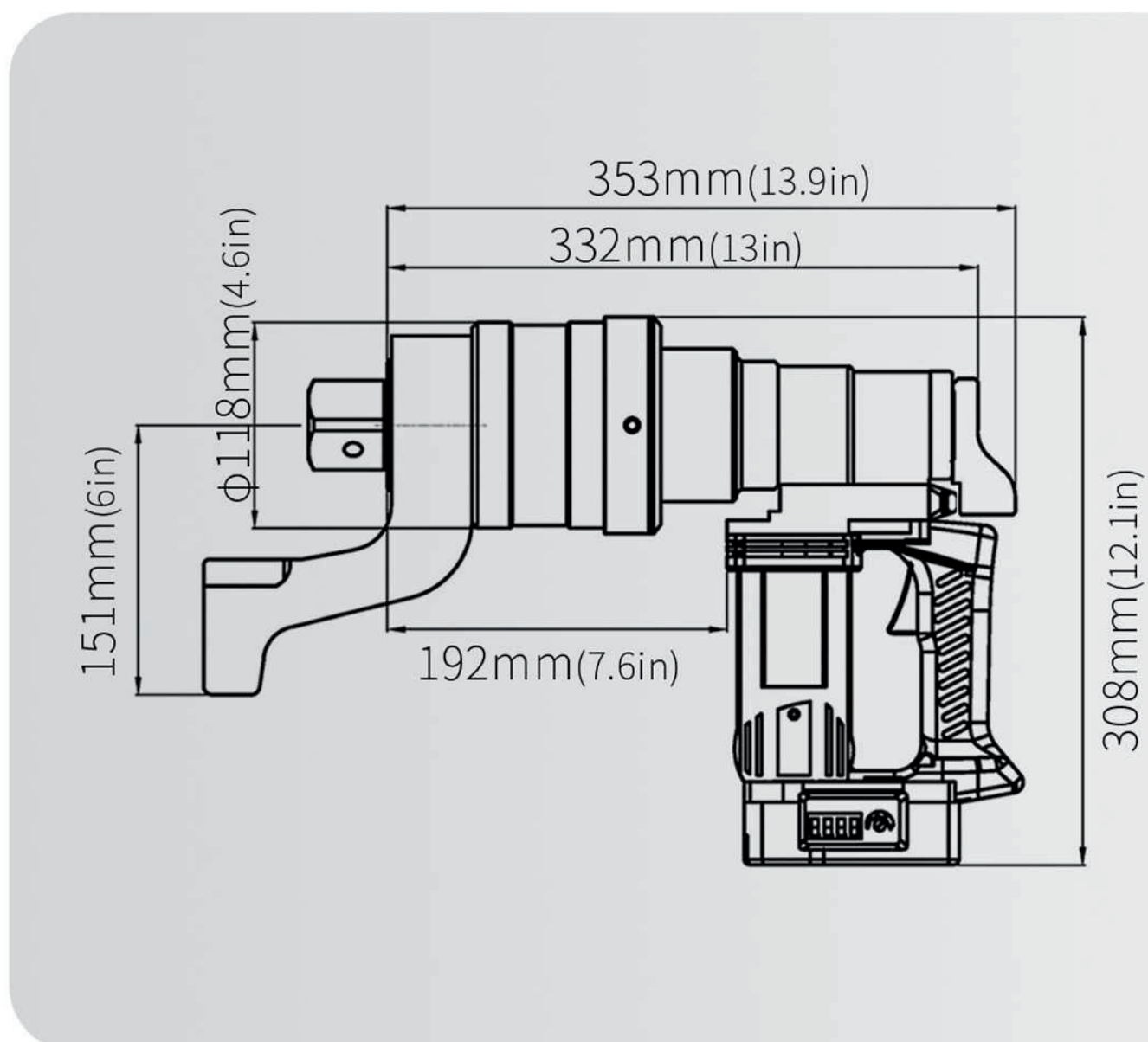

ELECTRIC TORQUE WRENCH BTDEC-100G

MODEL	MAX CURRENT	MAX POWER CONSUMPTION	TORQUE RANGE	RO SPEED (min-1)	WEIGHT (MAIN BODY)	SQUARE DRIVE	ADAPTABLE BOLTS DIA		
							S-10T	A325	A490
BTDEC-40G	12A 24A	2800W	1000-4000N.m 738-2952lbs.ft	4rpm	10.6KG	38X38mm (1-1/2"X1-1/2")	M27 M30 M33 M36 M42	1-1/8" 1-1/4" 1-3/8" 1-1/2" 1-5/8"	1-1/8" 1-1/4" 1-3/8" 1-1/2"
BTDEC-100G	8A 16A	1800W	3000-10000N.m 2214-7380lbs.ft	1.5rpm	14KG	38X38mm (1-1/2"X1-1/2")	M36 M42 M45 M48 M52 M56	1-1/2" 1-5/8" 1-3/4" 2" 2-1/8" 2-1/4"	1-1/2" 1-5/8" 1-3/4" 2" 2" 2-1/8"

wrench without socket

NEW

ELECTRIC TORQUE WRENCH

CHARACTERISTICS

Digital control torque, high repeated accuracy and stability. Can control both torque value and rotational angle. Torque and angle can be separately control, also can be controlled at the same time.

50-60Hz
220V/115V

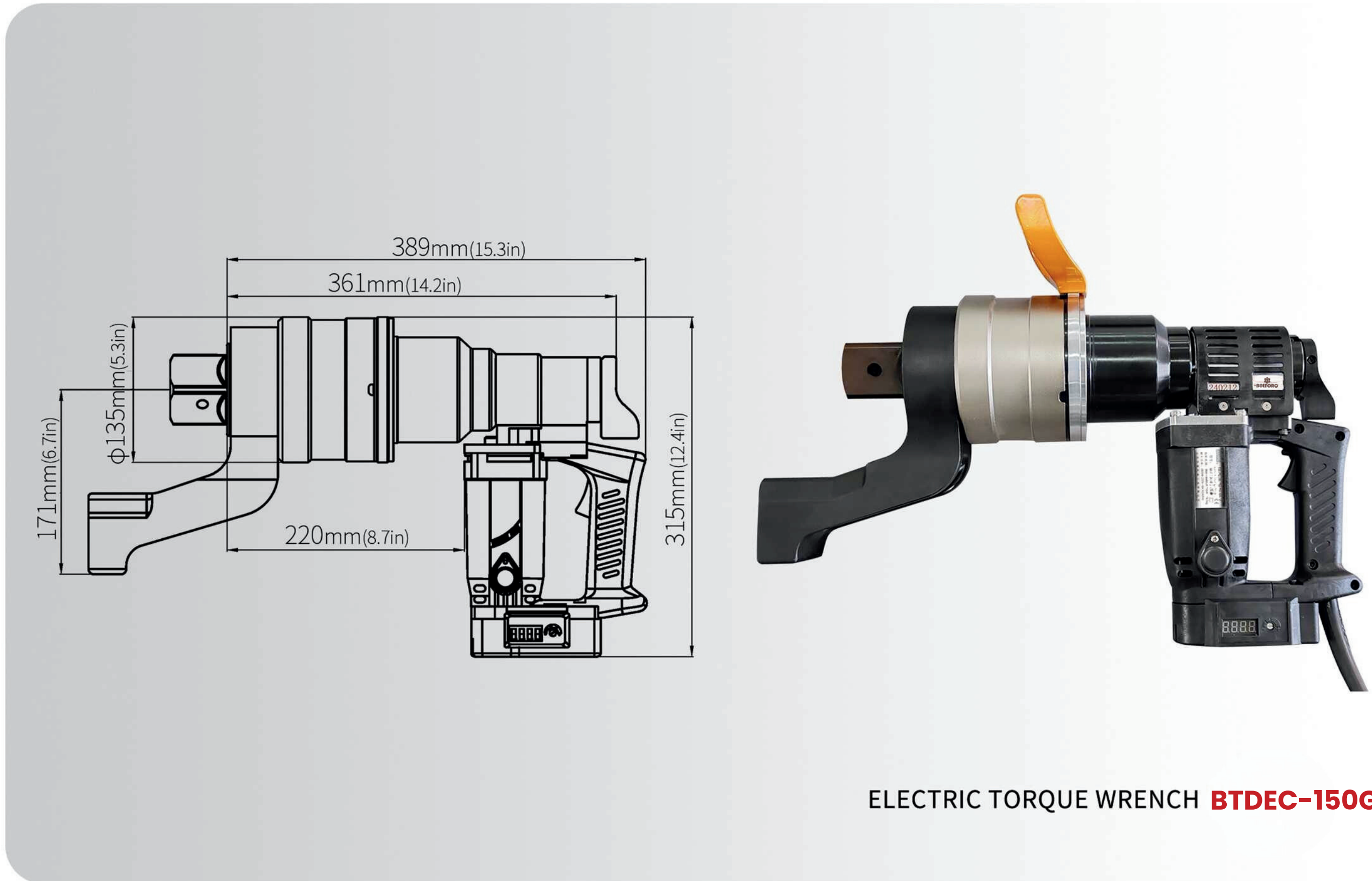
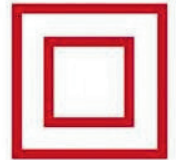

ELECTRIC TORQUE WRENCH **BTDEC-150G**

MODEL		BTDEC-150G
MAX CURRENT		12A/24A
MAX POWER CONSUMPTION		2800W
TORQUE RANGE		5000-15000N.m 3690-11070lbs.ft
RO SPEED(min-1)		1rpm
WEIGHT(MAIN BODY)		17KG
SQUARE DRIVE		50x50mm (2"x 2")
ADAPTABLE BOLTS DIA	S-10T	M45 M48 M52 M56 M60
	A325	1-3/4" 2" 2-1/8" 2-1/4" 2-1/2"
	A490	1-3/4" 2" 2-1/8" 2-1/4"

wrench without socket

GORMNER TYPE ELECTRIC TORQUE WRENCH

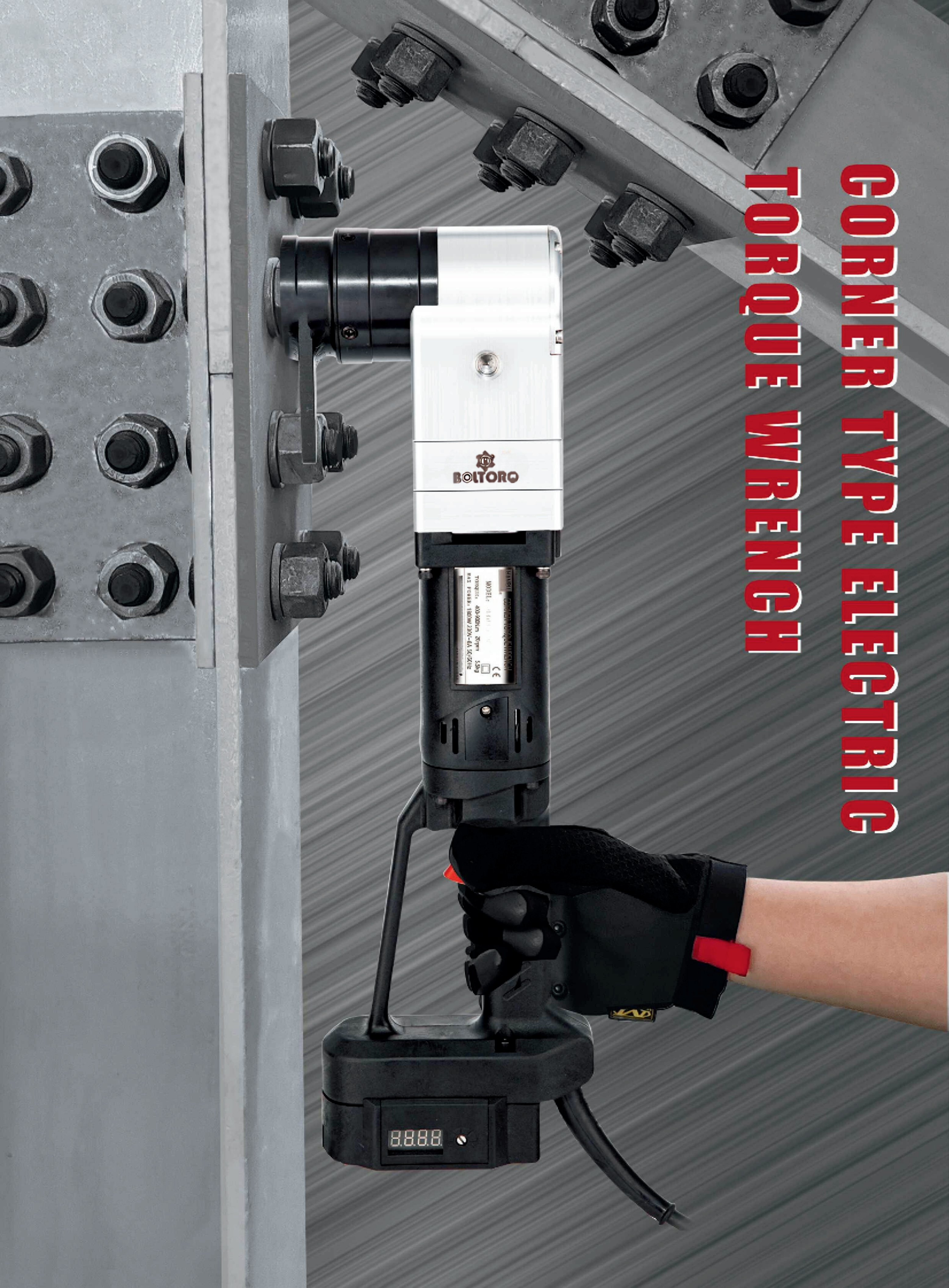



CORNER TYPE ELECTRIC TORQUE WRENCH



BOLTORQ
Inspiring Bolting Era, Accelerating Growth

CHARACTERISTICS

Special corner design, perfect for narrow space work.

50-60Hz
220V/115V

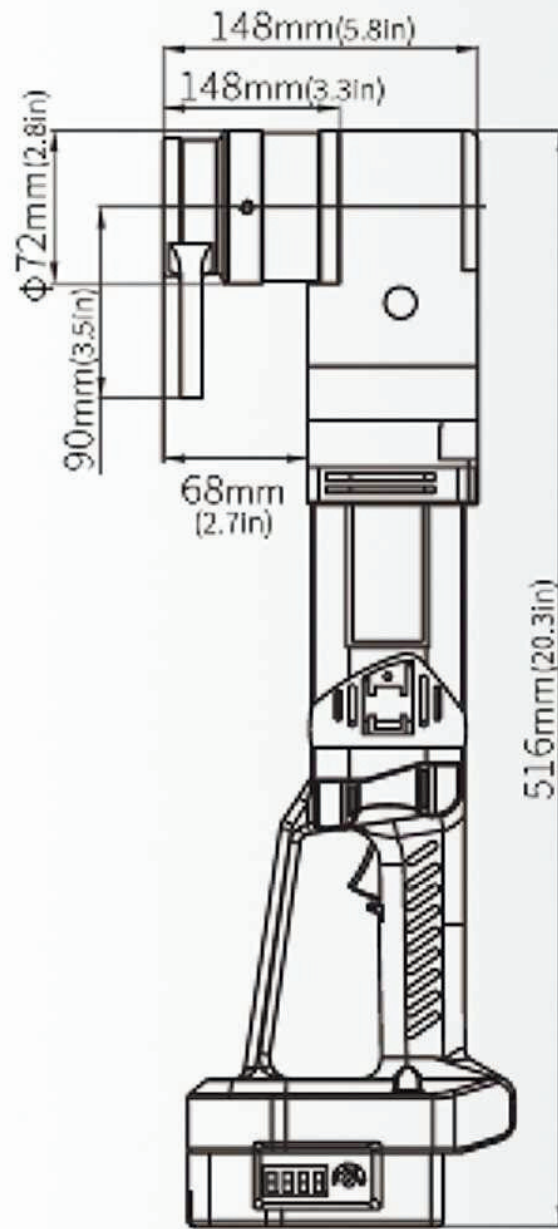
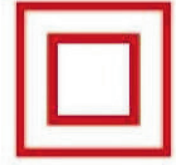

CORNER TYPE ELECTRIC TORQUE WRENCH **BTDEC-9B**

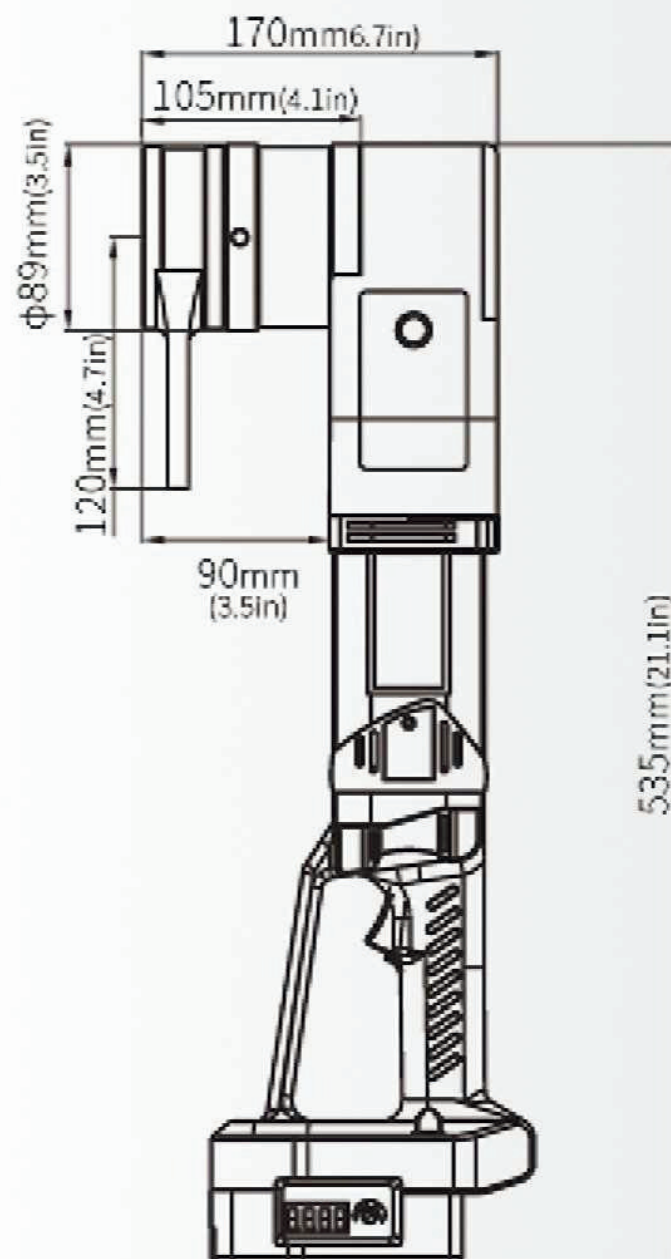

CORNER TYPE ELECTRIC TORQUE WRENCH **BTDEC-21B**

MODEL	MAX CURRENT	MAX POWER CONSUMPTION	TORQUE RANGE	RO SPEED (min ⁻¹)	WEIGHT (Main body)	ADAPTABLE BOLTS DIA		
						S-10T	A325	A490
BTDEC-9B	8A 16A	1800W	400-900N.m 295-664lbs.ft	20rpm	5.5KG	M20 M22 M24	3/4" 7/8" 1"	3/4" 7/8"
BTDEC-21B	8A 16A	1800W	900-2100N.m 664-1550lbs.ft	8rpm	7KG	M27 M30	1-1/8" 1-1/4"	1-1/8"

Each wrench provide 1 socket,it will be set on the wrench.